

Intelligent battery sensor: E60, E61, E63, E64

meeknet.co.uk/e64

Installation location

The intelligent battery sensor (IBS) is installed at the negative terminal of the battery.

Example: E60

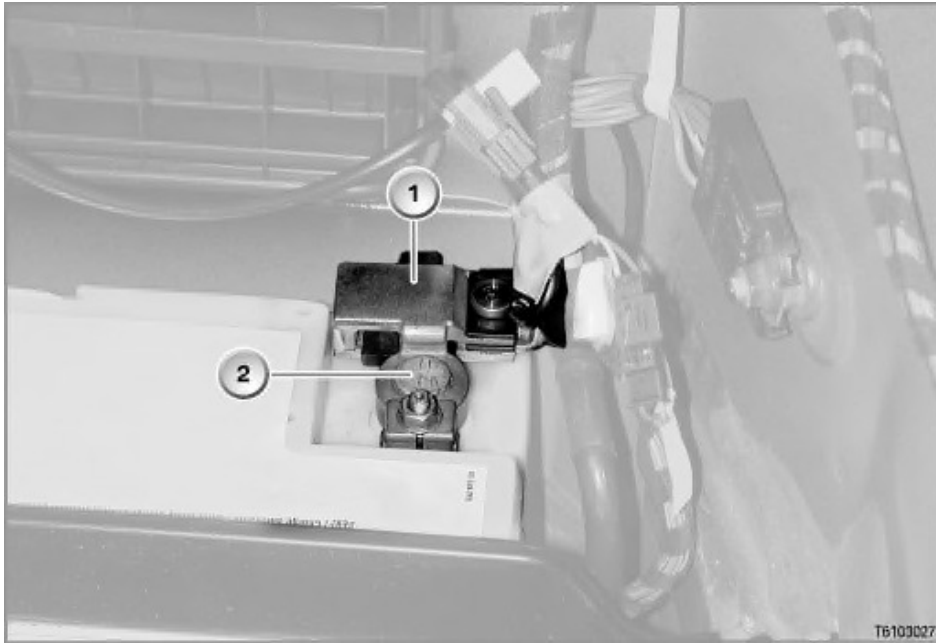

Item	Description	Item	Description
1	Intelligent battery sensor (IBS)	2	Battery negative terminal

Construction

The intelligent battery sensor (IBS) is an intelligent, mechatronic component that monitors the battery condition. The power supply to the IBS is provided through a separate wire. For the purpose of data transmission, the IBS is connected to the digital engine electronics (DME) or digital diesel electronics (DDE) via the bitserial data interface (BSD).

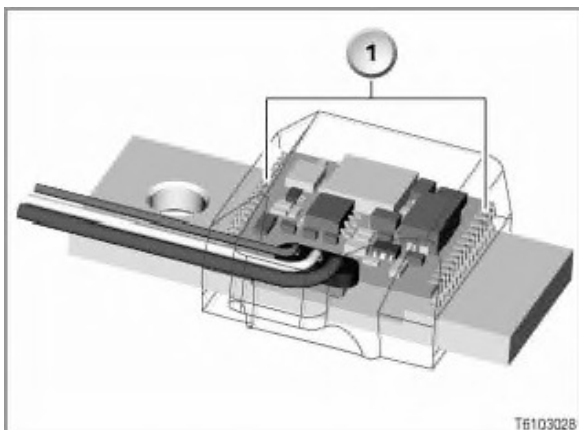

- 1 Spring element (gull wings) on intelligent battery sensor (IBS)

The intelligent battery sensor (IBS) consists of mechanical components, the electronics module and software.

- Mechanical components

The battery terminal with earth cable is the connection to the negative terminal of the battery and serves

- to create an electrical contact to the body
- as the support for the sensor element for current measurements
- as the support for the electronic module
- to provide an adequate thermal contact between the temperature sensor and the negative terminal of

the battery

- as protection for the sensitive electronic module
- as an earth connection for the IBS

The mechanical parts and the electronic module of the IBS are illustrated below.

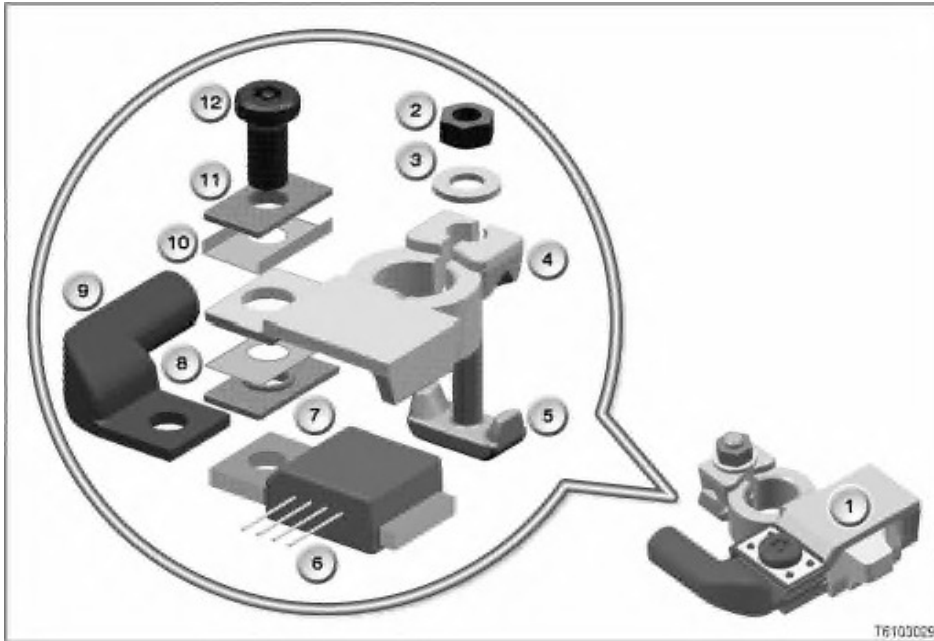

Item	Description	Item	Description
1	Battery negative terminal with intelligent battery sensor (IBS)	2	Nut
3	Shim	4	Part of battery negative terminal
5	Screw	6	Electronics module
7	Pressure plate	8	Insulator
9	Cable shoe for battery negative wire	10	Insulator
11	Pressure plate	12	Torx screw

- Electronic module

The electronic module has the task of recording the voltage, the current flow and the temperature of the battery. The following components are housed in the electronic module:

- a shunt (resistance for current measurement)
- a temperature sensor
- an electronic evaluation unit on a board

The board, which is about the size of a fingernail, contains an electronic circuit for evaluating the data measured.

The intelligent battery sensor (IBS) is able to withstand thermal loads of up to 105 °C and the chemical effect of the battery acid. The IBS thus satisfies the necessary conditions for installation in the engine or luggage compartment.

The components of the shunt are illustrated below.

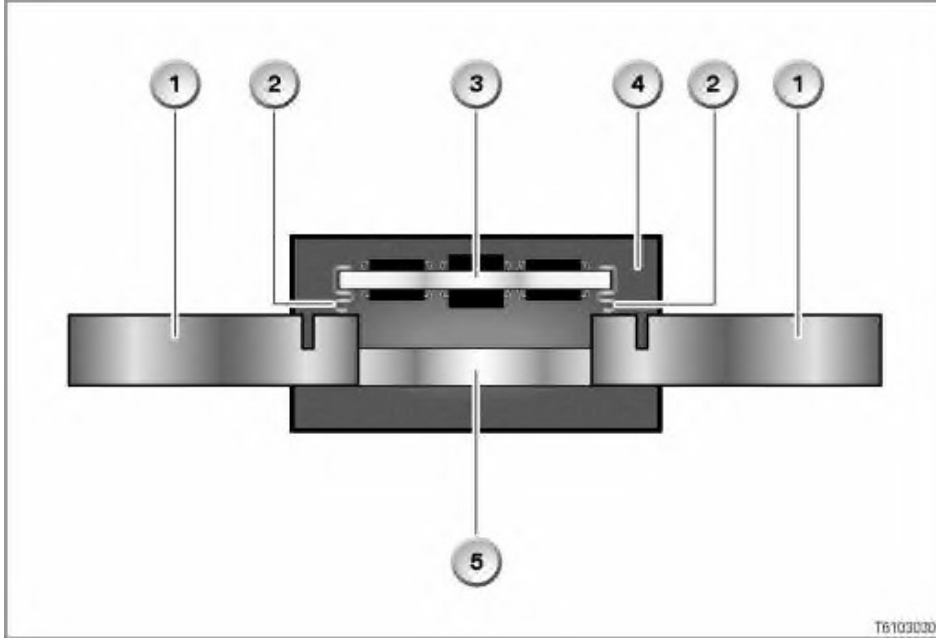

Item	Description	Item	Description
1	Copper	2	Spring element (gull wings)
3	Board with electronic evaluation unit	4	Injection-moulded surround
5	Manganin resistance (resistance alloy)		

- Software
The program in the microcontroller of the intelligent battery sensor (IBS)

How it works

The functions of the intelligent battery sensor (IBS) are:

- To continuously measure battery data in all vehicle operating modes
- To compute battery indicators as basis for battery charge state (SoC: "State of Charge") and battery condition (SoH: "State of Health")
- To balance the charge/discharge current of the battery
- To monitor the battery's charge state (SoC) and to activate the electric energy management and power management for countermeasures if the battery charge state becomes critical (battery's limit of starting capability).
- To identify initial data for calibrating the battery charge state (SoC: "State of Charge")
- To calculate the starting current curve to determine the battery condition (SoH: "State of Health")
- To monitor off-load current
- To transmit data to the higher-order control unit (DME or DDE)
- Self-diagnosis
- To perform fully automatic updates of algorithm parameters and parameters for self-diagnosis via DME / DDE
- To be able to independently "wake up" from sleep mode

The individual functions of the IBS are illustrated below as function blocks in the overall function of the IBS. The processes are elucidated by the arrows.

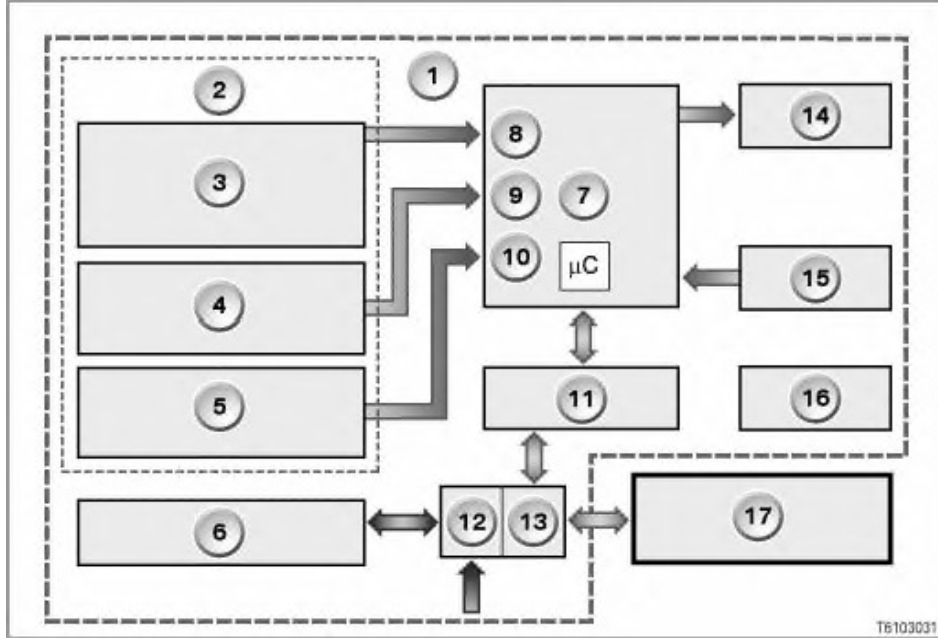

Item	Description	Item	Description
1	Intelligent battery sensor (IBS) complete function	2	Measurement of battery data: - Current - Voltage - Temperature
3	Current measurement, measuring range of IBS: - Operating current: -200 A to +220 A - Off-load current: 0 A to 10 A - Starting current: 0 A to 1000 A	4	Voltage measurement, measuring range of IBS: 6 V to 16.5 V
5	Temperature measurement, measuring range of IBS: -40°C to +105°C	6	Internal voltage regulator for IBS
7	Data processing using microcontroller Communication via bit-serial data interface (BSD)	8	Calculation of battery indicators
9	Partial calculation of battery charge state and battery condition	10	Management of auxiliary consumers
11	Driver for bit-serial data interface (BSD) with "wake-up" function	12	Battery voltage
13	Bit-serial data interface (BSD)	14	Terminal 15 wake-up wire
15	Internal "wake-up" function	16	EEPROM (Electrically Erasable Programmable Read-Only Memory)
17	Digital engine electronics (DME) or digital diesel electronics (DDE)	18	

The principle for measuring and processing the battery values is illustrated below.

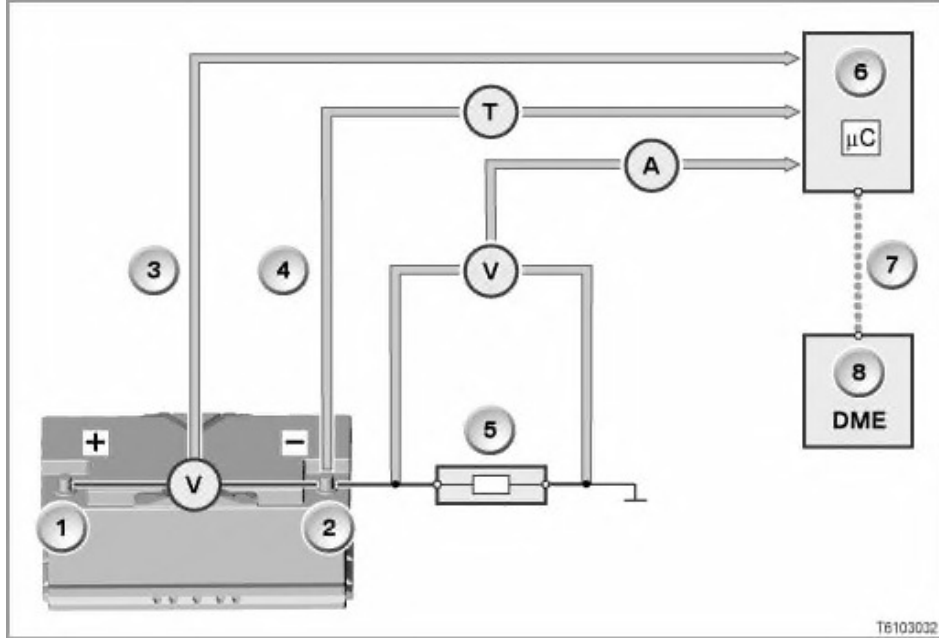

Item	Description	Item	Description
1	Battery positive terminal	2	Battery negative terminal
3	Measurement of battery voltage between battery positive terminal and battery negative terminal	4	Measurement of battery temperature (T)
5	Measurement of current (A) [indirect, via the proportional voltage drop (V) at the shunt]	6	Microcontroller (μC) in intelligent battery sensor (IBS)
7	Bitserial data interface (BSD) for transmitting data to DME	8	Digital engine electronics (DME)

Electronic evaluation unit

The electronic evaluation unit in the IBS (intelligent battery sensor) continuously records the measured data. The IBS uses this data to calculate the battery indicators

- Voltage
- Current
- Temperature

The IBS transmits the battery indicator data to the DME or DDE via the bit-serial data interface (BSD). Parallel to the calculation of the battery indicators, a preliminary calculation of the battery's state of charge (SoC) is made.

In the time between engine OFF and DME main relay shutdown, the IBS receives information about the maximum charge available for a reliable engine start from the DME/DDE. The IBS continuously monitors the battery charge state (SoC) when the DME main relay has been switched off.

The message "Auxiliary consumers OFF" from the DME/DDE instructs auxiliary consumers that are switched on to switch themselves off when the critical battery charge state (battery's limit of starting capability) is reached.

Charge balance through IBS

When the vehicle is out of use, the IBS continuously balances the battery charge state (SoC: "State of Charge").

From terminal 15 ON, the DME/DDE receives updated information about the battery indicators (battery condition "SoH"; battery charge state "SoC").

Off-load current measurement

When the vehicle is not in use, the IBS continuously monitors the data relevant to the battery indicators. The IBS is programmed to "wake up" every 14 seconds so that it can update the measured values with new measurements. The measuring time is approx. 50 milliseconds (ms). The measured data are entered in the IBS memory for monitoring the off-load current.

When the engine is restarted, the DME / DDE reads off the off-load current curve. In the event of a deviation from

the defined off-load current curve, an entry will be made in the DME / DDE fault memory.

Terminal 15 wake-up function

The terminal 15 wake-up function is only applicable when the vehicle is not in use. The function sequence is as follows:

- When "terminal 15 OFF" has been received, the DME / DDE informs the IBS of the maximum battery charge quantity available.
 - After issuing the message about the maximum charge quantity available, the DME / DDE will go into sleep mode.
- If the maximum battery charge quantity available has been reached and auxiliary consumers are switched on, the IBS will "wake up" the vehicle (and thus the DME / DDE) via the wake-up wire (terminal 15 wake-up).
- When the battery's critical charge state has been reached (battery's limit of starting capability), the DME / DDE instructs the auxiliary consumers to switch themselves off.
- The DME / DDE no longer allows the IBS to "wake up" the vehicle.
- The vehicle then goes back into sleep mode.

The control units connected to the terminal 15 wake-up function are illustrated below.

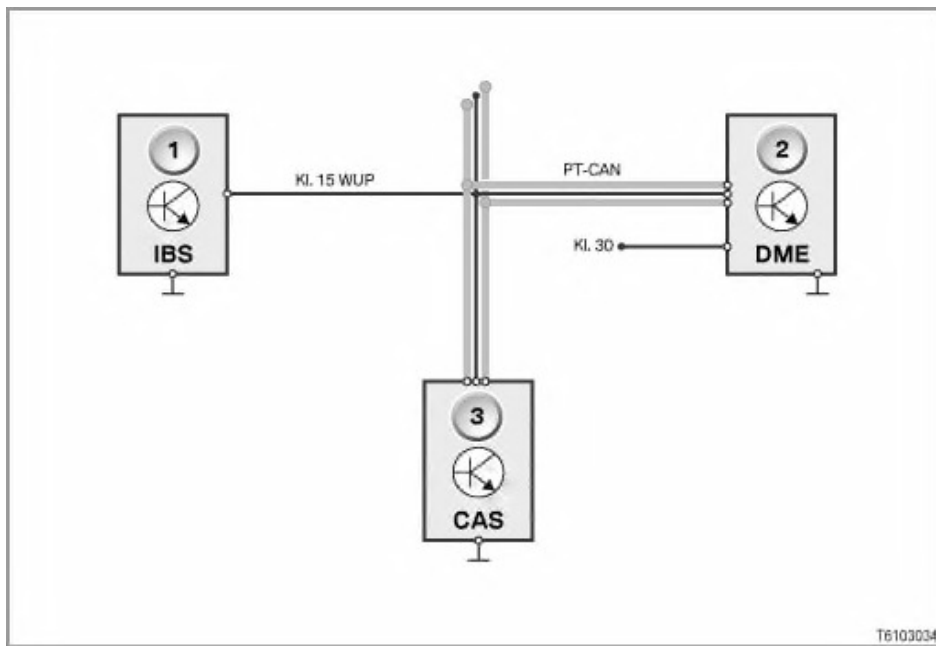

Item	Description	Item	Description
1	Intelligent battery sensor (IBS)	2	Digital engine electronics (DME)
3	Car Access System (CAS)	KI. 30	Terminal 30
PT-CAN	Powertrain CAN	KI. 15 WUP	Terminal 15 wake-up wire